

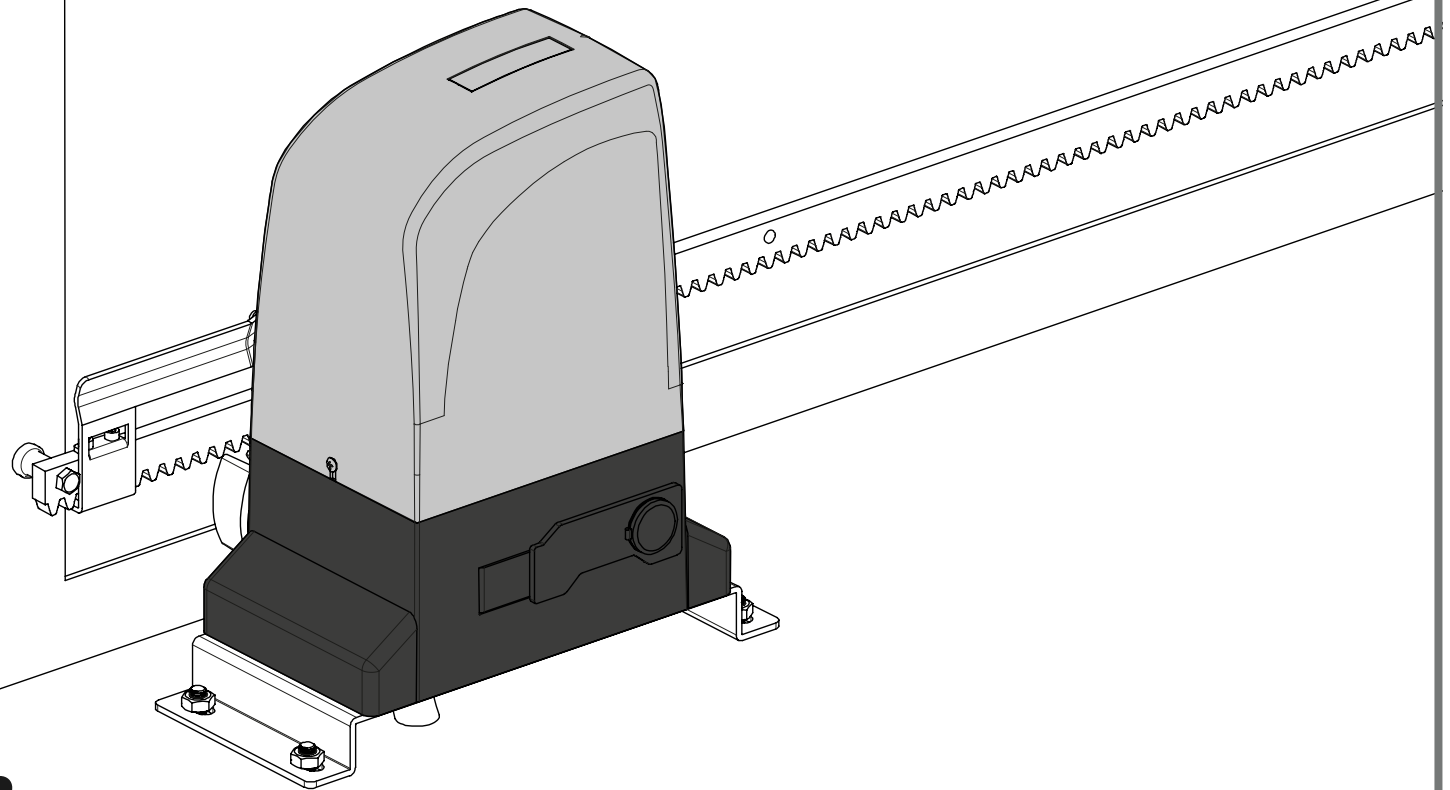

SLIDE & OL

USER'S AND INSTALLER'S MANUAL



motorline[®]
PROFESSIONAL









00. CONTENT

INDEX

01. SAFETY INSTRUCTIONS	
STANDARDS TO FOLLOW	1B
02. OPERATOR	
TECHNICAL SPECIFICATIONS	4A
DESCRIPTION	4A
DIMENSIONS	4B
DESCRIPTION OF THE SYSTEM	4B
ACCESSORIES	5A
INSTALLATION TOOLS	5A
03. INSTALLATION	
PRELIMINARY CHECKS	5A
PREPARING THE FOUNDATION PLATE	5B
POSITIONING THE OPERATOR	5B
FIXING OPERATOR	6A
RELEASING THE OPERATOR	6B
INSTALLING THE RACK	6B
INSTALLING LIMIT SWITCH PLATE	7A
MAINTENANCE AND REPAIRS	7A
CLUTCH ADJUSTMENT	7B
04. CONNECTIONS OF THE MOTOR	
FOR 800A/OL1500	8A
FOR OL2000	8B

01. SAFETY INSTRUCTIONS

	This product is certified in accordance with European Community (EC) safety standards.
	This product complies with Directive 2011/65/EU of the European Parliament and of the Council, of 8 June 2011, on the restriction of the use of certain hazardous substances in electrical and electronic equipment and with Delegated Directive (EU) 2015/863 from Commission.
	(Applicable in countries with recycling systems). This marking on the product or literature indicates that the product and electronic accessories (eg. Charger, USB cable, electronic material, controls, etc.) should not be disposed of as other household waste at the end of its useful life. To avoid possible harm to the environment or human health resulting from the uncontrolled disposal of waste, separate these items from other types of waste and recycle them responsibly to promote the sustainable reuse of material resources. Home users should contact the dealer where they purchased this product or the National Environment Agency for details on where and how they can take these items for environmentally safe recycling. Business users should contact their vendor and check the terms and conditions of the purchase agreement. This product and its electronic accessories should not be mixed with other commercial waste.
	This marking indicates that batteries should not be discarded like other household waste at the end of their useful life. Batteries must be delivered to selective collection points for recycling.
	The different types of packaging (cardboard, plastic, etc.) must be subject to selective collection for recycling. Separate packaging and recycle it responsibly.
	This marking indicates that the product and electronic accessories (eg. charger, USB cable, electronic material, controls, etc.) are susceptible to electric shock by direct or indirect contact with electricity. Be cautious when handling the product and observe all safety procedures in this manual.

01. SAFETY INSTRUCTIONS

GENERAL WARNINGS

- This manual contains very important safety and usage information. Read all instructions carefully before beginning the installation/usage procedures and keep this manual in a safe place that it can be consulted whenever necessary.
- This product is intended for use only as described in this manual. Any other enforcement or operation that is not mentioned is expressly prohibited, as it may damage the product and put people at risk causing serious injuries.
- This manual is intended firstly for specialized technicians, and does not invalidate the user's responsibility to read the "User Norms" section in order to ensure the correct functioning of the product.
- The installation and repair of this product may be done by qualified and specialized technicians, to assure every procedure are carried out in accordance with applicable rules and norms. Nonprofessional and inexperienced users are expressly prohibited of taking any action, unless explicitly requested by specialized technicians to do so.
- Installations must be frequently inspected for unbalance and the wear signals of the cables, springs, hinges, wheels, supports and other mechanical assembly parts.
- Do not use the product if it is necessary repair or adjustment is required.
- When performing maintenance, cleaning and replacement of parts, the product must be disconnected from power supply. Also including any operation that requires opening the product cover.
- The use, cleaning and maintenance of this product may be carried out by any persons aged eight years old and over and persons whose physical, sensorial or mental capacities are lower, or by persons without any knowledge of the product, provided that these are supervision and instructions given by persons with experienced in terms of usage of the product in a safe manner and who understands the risks and dangers involved.

01. SAFETY INSTRUCTIONS

WARNINGS FOR TECHNICIANS

- Children shouldn't play with the product or opening devices to avoid the motorized door or gate from being triggered involuntarily.
- If the power cable is damaged, it must be replaced by the manufacturer, after-sales service or similarly qualified personnel to avoid danger.
- The device must be disconnected from the electrical network when removing the battery.
- Ensure that blocking is avoided between the actuated part and its fixed parts due to the opening movement of the actuated part.

- Before beginning the installation procedures, make sure that you have all the devices and materials necessary to complete the installation of the product.
- You should note your Protection Index (IP) and operating temperature to ensure that is suitable for the installation site.
- Provide the manual of the product to the user and let them know how to handle it in an emergency.
- If the automatism is installed on a gate with a pedestrian door, a door locking mechanism must be installed while the gate is in motion.
- Do not install the product "upside down" or supported by elements do not support its weight. If necessary, add brackets at strategic points to ensure the safety of the automatism.
- Do not install the product in explosive site.
- Safety devices must protect the possible crushing, cutting, transport and danger areas of the motorized door or gate.
- Verify that the elements to be automated (gates, door, windows, blinds, etc.) are in perfect function, aligned and level. Also verify if the necessary mechanical stops are in the appropriate places.
- The control board must be installed on a safe place of any fluid (rain, moisture, etc.), dust and pests.
- You must route the various electrical cables through protective tubes, to protect them against mechanical exertions, essentially on

01. SAFETY INSTRUCTIONS

the power supply cable. Please note that all the cables must enter the control board from the bottom.

- If the automatism is to be installed at a height of more than 2,5m from the ground or other level of access, the minimum safety and health requirements for the use of work equipment workers at the work of Directive 2009/104/CE of European Parliament and of the Council of 16 September 2009.
- Attach the permanent label for the manual release as close as possible to the release mechanism.
- Disconnect means, such as a switch or circuit breaker on the electrical panel, must be provided on the product's fixed power supply leads in accordance with the installation rules.
- If the product to be installed requires power supply of 230Vac or 110Vac, ensure that connection is to an electrical panel with ground connection.
- The product is only powered by low voltage safety with control board (only at 24V motors).
- Parts/products weighing more than 20 kg must be handled with special care due to the risk of injury. It is recommended to use suitable auxiliary systems for moving or lifting heavy objects.
- Pay special attention to the danger of falling objects or uncontrolled movement of doors/gates during the installation or operation of this product.

WARNINGS FOR USERS

- Keep this manual in a safe place to be consulted whenever necessary.
- If the product has contact with fluids without being prepared, it must immediately disconnect from the power supply to avoid short circuits, and consult a specialized technician.
- Ensure that technician has provided you the product manual and informed you how to handle the product in an emergency.
- If the system requires any repair or modification, unlock the automatism, turn off the power and do not use it until all safety

01. SAFETY INSTRUCTIONS

conditions have been met.

- In the event of tripping of circuits breakers or fuse failure, locate the malfunction and solve it before resetting the circuit breaker or replacing the fuse. If the malfunction is not repairable by consult this manual, contact a technician.
- Keep the operation area of the motorized gate free while the gate in in motion, and do not create strength to the gate movement.
- Do not perform any operation on mechanical elements or hinges if the product is in motion.

RESPONSABILITY

- Supplier disclaims any liability if:
 - Product failure or deformation result from improper installation use or maintenance!
 - Safety norms are not followed in the installation, use and maintenance of the product.
 - Instructions in this manual are not followed.
 - Damaged is caused by unauthorized modifications
 - In these cases, the warranty is voided.

MOTORLINE ELECTROCELOS SA.

Travessa do Sobreiro, nº29
4755-474 Rio Côvo (Santa Eugénia)
Barcelos, Portugal

SYMBOLS LEGEND:



• Important safety notices



• Useful information



• Programming information



• Potentiometer information



• Connectors information



• Buttons information

02. OPERATOR

TECHNICAL SPECIFICATIONS

Technical specifications of the automated operator:

	800A		OL1500		OL2000	
	110V	230V	110V	230V	110V	230V
• Power supply	110V, 60Hz	230V, 50Hz	110V, 60Hz	230V, 50Hz	110V, 60Hz	230V, 50Hz
• Rated absorbed power	370W		550W		1000W	
• Max speed	186mm/snd		186mm/snd		186mm/snd	
• Noise	≤ 56dB		≤ 56dB		≤ 56dB	
• Operating temperature	>-25°C, <65°C		>-25°C, <65°C		>-25°C, <65°C	
• Protection class	IP44		IP44		IP44	
• Thermal protection (°C)	120°C		120°C		120°C	
• Leaf max weight (Kg)	800Kg		1500Kg		2000Kg	
• Working frequency	40%		70%		70%	
• Capacitor	35µF	12uF	60µF	16uF	25µF and 70µF	12,5uF and 25uF

DESCRIPTION



- Automated system for residential or industrial sliding gates with a maximum of 2000kgs. It consists of a reversing electro-mechanical gearmotor, powered by a 110 or 230V control unit.
- The automated system houses a programmable electronic control board that enables setting of function logics, work time and pause time, anti-crushing sensitivity as well as partial-opening width.
- The reversing system guarantees the gate will automatically lock when the motor is not operating.
- A release system enables the gate to be moved by hand in case of malfunction or emergency.
- The automated system was designed and built for controlling sliding gates. Do not use for any other purpose.

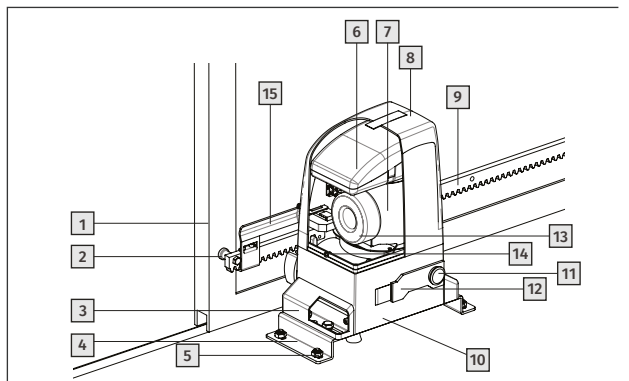

- 1 • Gate
- 2 • Rack spacer
- 3 • Protective cover
- 4 • Foundation plate
- 5 • Fixation screw
- 6 • Control box
- 7 • Motor
- 8 • Cover
- 9 • Rack
- 10 • Housing
- 11 • Lock
- 12 • Manual release
- 13 • Capacitor
- 14 • Screw
- 15 • Limit switch plate

02. OPERATOR

DIMENSIONS

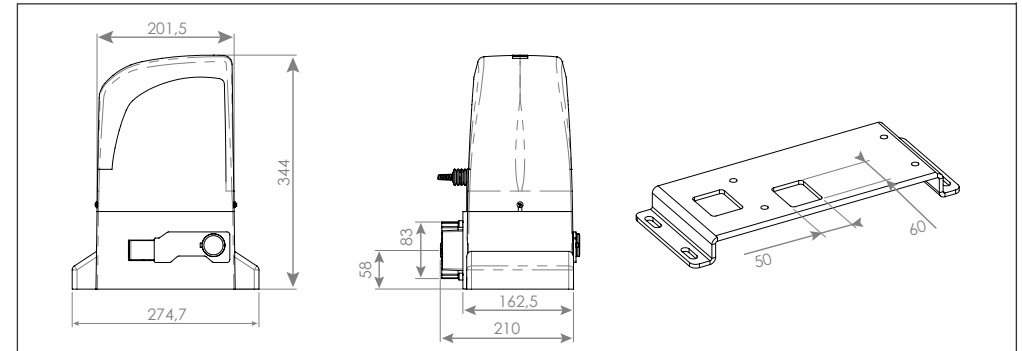

DESCRIPTION OF THE SYSTEM

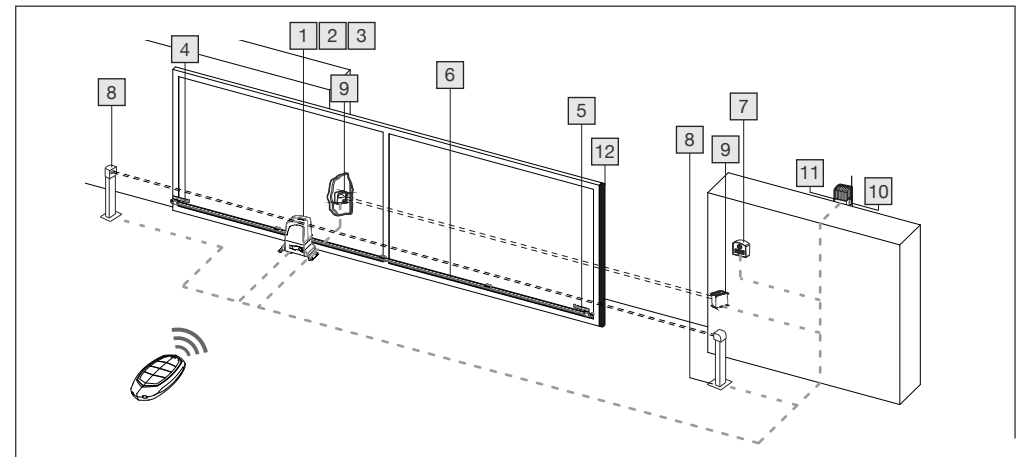

- | | | |
|-----------------------------|------------------------------|-----------------------|
| 1 • Motor | 5 • Right limit switch plate | 9 • Safety photocells |
| 2 • Control board | 6 • Rack | 10 • Antenna |
| 3 • Receiver | 7 • Key selector | 11 • Warning light |
| 4 • Left limit switch plate | 8 • Photocell column | 12 • Safety edge |



- To lay down electric cables, use rigid and/or flexible adequate tubes.
- 2) To avoid any kind of interference, always separate low voltage connection cables from AC110 or 230V power cables.
 - 3) The description of system is standard system, but we did not provide all parts. If you want system accessories, please contact us.

02. OPERATOR

ACCESSORIES

You must check the operator packing before installing the automated system.

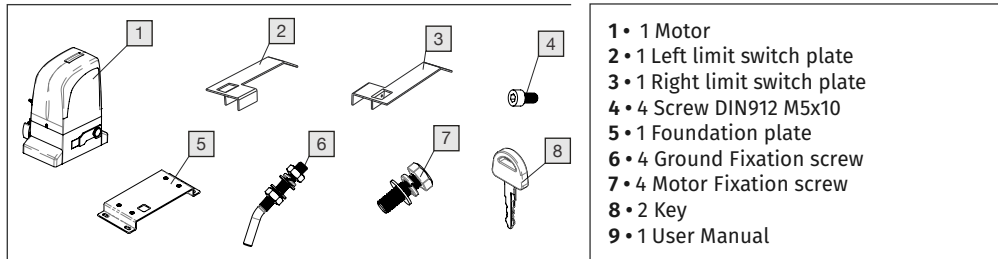

- 1 • 1 Motor
- 2 • 1 Left limit switch plate
- 3 • 1 Right limit switch plate
- 4 • 4 Screw DIN912 M5x10
- 5 • 1 Foundation plate
- 6 • 4 Ground Fixation screw
- 7 • 4 Motor Fixation screw
- 8 • 2 Key
- 9 • 1 User Manual

INSTALLATION TOOLS

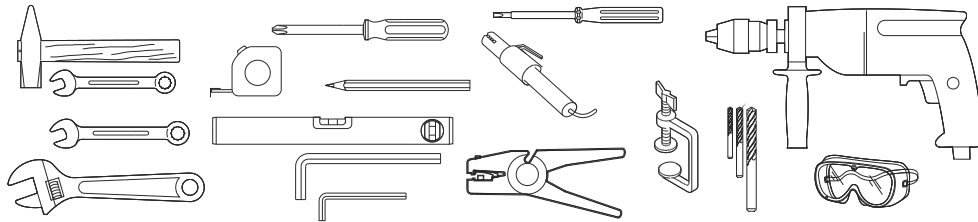

03. INSTALLATION

PRELIMINARY CHECKS



To ensure safety and an efficiently operating automated system, make sure the following conditions are applied:

- The structure of the gate must be suitable for being automated. In particular, check that the structure is sufficiently strong and rigid, and that its dimensions and weight conform to those indicated in the technical specifications;
- Make sure that the gate slides without any inclination;
- Make sure that the gate moves uniformly and correctly, without any irregular friction during its entire travel;
- The soil must permit sufficient stability for the expansion plugs securing the foundation plate;
- Remove any locks and lock bolts. We advise you to have any metalwork carried out before the automated system is installed.

03. INSTALLATION

PREPARING THE FOUNDATION PLATE

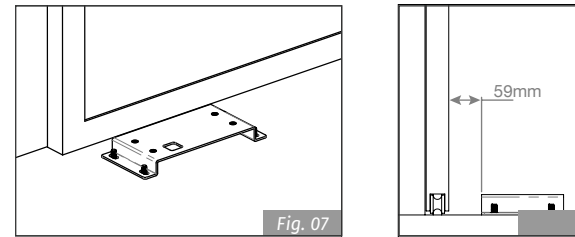

Fit the 4 supplied nuts, as shown in Fig. 07 and Fig. 08, in the 4 holes of the plate.

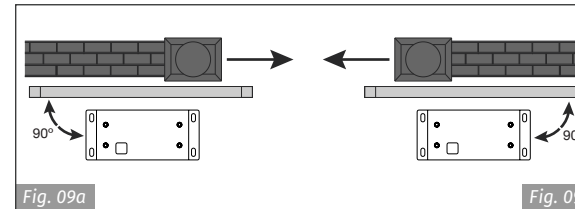

1 • The foundation plate must be located as shown in Fig. 9a (right closing) or Fig. 9b (left closing) to ensure the rack and pinion match correctly.

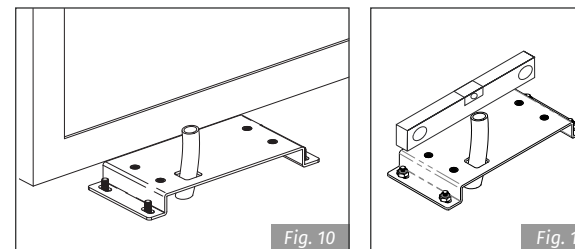

2 • Put the foundation plate to the floor, using adequate expansion plugs and provide one or more tubes for routing the electric cables through the plate (Fig 10 and 11). Using a level, check if the plate is perfectly horizontal.

POSITIONING THE OPERATOR

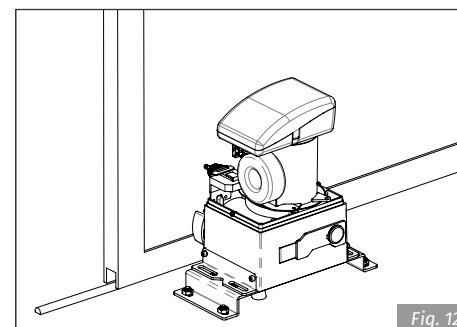

Lay the electric cables to connect motor to accessories and power supply as shown in Fig. 4. To facilitate making the connections, allow the cables to project by the required length for connection to the control board, transformer and etc (if provided). Position the operator on the plate, using the supplied screws as shown in Fig. 12.

03. INSTALLATION

POSITIONING THE OPERATOR

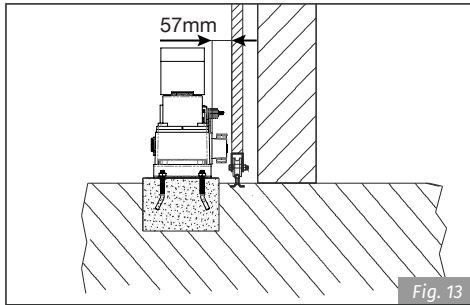

Adjust the distance of the operator from the gate by referring to Fig.13.

FIXING OPERATOR

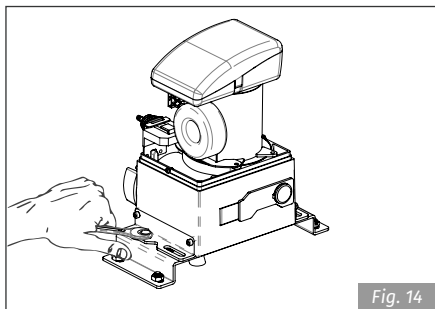
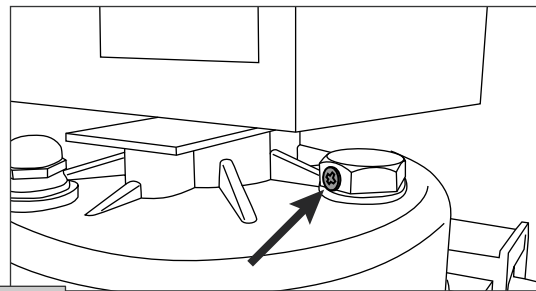

Fig. 14

1 • Fix the operator slightly tightening the screws as shown in Fig. 14.



After the installation, you must remove the exhaust screw (Applicable in OL1500 and 2000).

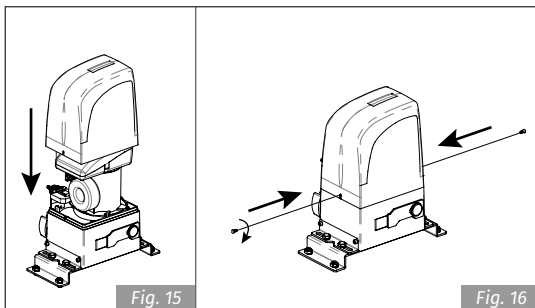

Fig. 15

Fig. 16

2 • After fixing the motor, screw cover (Fig. 15 and 16).

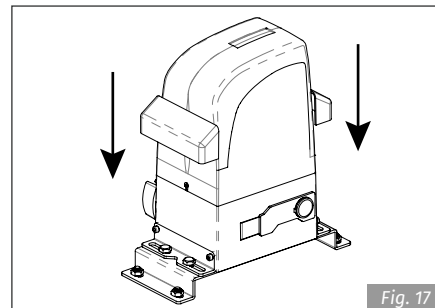

Fig. 17

3 • After the upper-cover fixed, please install the side-cover (Fig. 17).

03. INSTALLATION

RELEASING THE OPERATOR

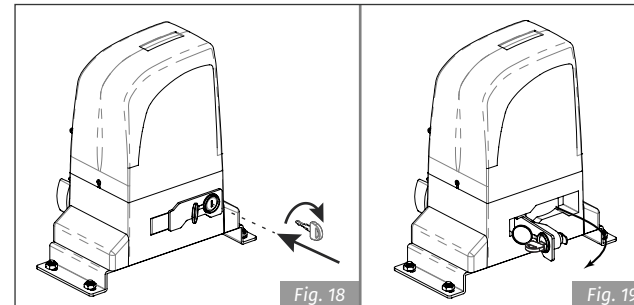

Fig. 18

Fig. 19

Insert supplied key on the lock, turn it clockwise 90° (Fig.18), pull and open the manual release (Fig.19).

After opened the manual release, you can operate the door manually.

INSTALLING THE RACK

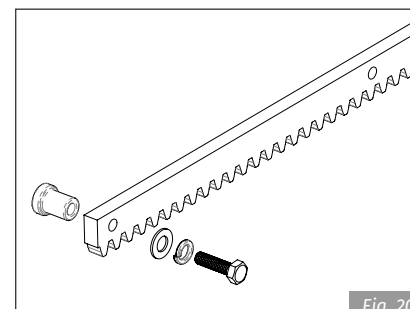

Fig. 20

1 • Prepare the rack to be applied. Putting these spacers in all holes of the rack in order to be completely secure.

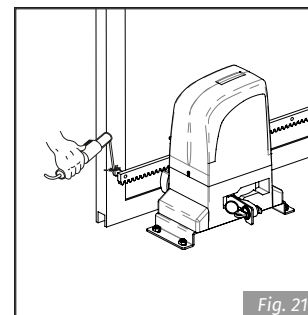

Fig. 21

2 • Manually put the gate leaf in the closed position.

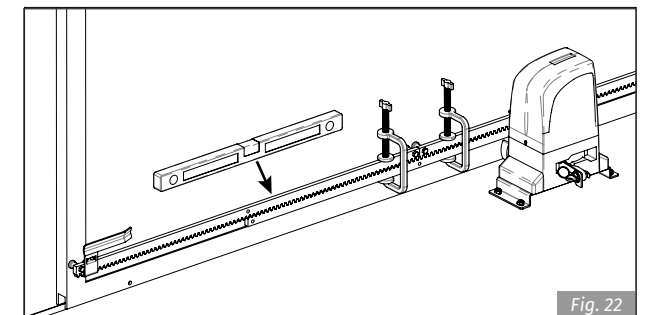

Fig. 22

3 • Positioning the first rack part to be bolted, supported on the pinion and with help of the level and clamping tool, keep it horizontally leveled.

4 • Move the gate to manually back and forth, to ensure that the gear rack is properly seated on the pinion and movement occurs smoothly.

5 • Set the rack in the gate. (Fig. 21). To ensure a correct fixation, can go slowly moving the gate and setting the gate spacers always near the pinion.

03. INSTALLATION

INSTALLING THE RACK

- 6 • Pull another element of the rack above, using a piece of additional rack teeth to synchronize the two elements (Fig. 22).
- 7 • Use a level again to make sure that rack is perfectly level.
- 8 • Manually move the gate and carry out the operations of attachment such as with the first element, proceeding up to the end of the gate.



- This motor can work with all types of racks.
- When installing nylon rack, make the application following the same steps described in the previous paragraphs. Start by placing the gate in the closed position, support the first meter of rack pinion on the engine and keeping it level horizontally, screw the first screw. Go opening the gate and tightening the remaining bolts. Continue adding more rack parts and repeating the same steps to complete the installation.
- Make sure that, during the gate travel, all the rack elements mesh correctly with the pinion.
- Do not, on any occasion, weld the rack elements either to the spacers. For fixing these, use screws and washers like in the Fig.20.
- Do not use grease or other lubricants between rack and pinion.

INSTALLING LIMIT SWITCH PLATE

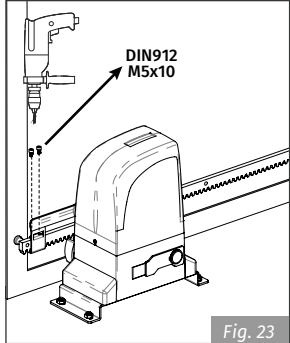

Fig. 23

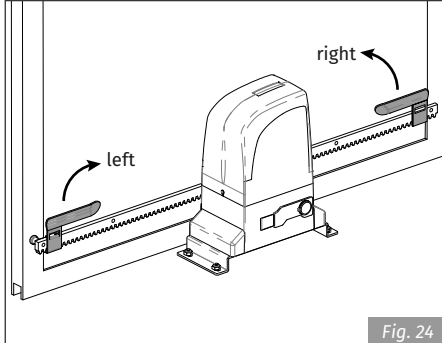

Fig. 24

- 1 • After having rack installed, take the gate back to the closed position and position the limit switch plate on the rack. In this closed position, the plate should trigger the limit switch of the motor.
- 2 • Tighten the screws DIN912 M5x12 included in the pack, until it touches the rack, squeezing it.

- 3 • Move the gate to the open position and repeat the same process for the other limit switch plate.
- 4 • The limit switch plates should be installed as in Fig. 24.

MAINTENANCE AND REPAIRS



- Carry out the following operations at least every 6 months:
- Check the efficiency of the release system.
 - Check the efficiency of the safety devices and accessories.
- For any repairs, pls contact the authorised repair centers.

03. INSTALLATION

CLUTCH ADJUSTMENT

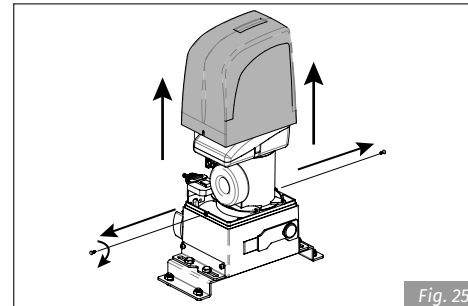

Fig. 25

- 1 • Unbolt the screws and remove the cover.

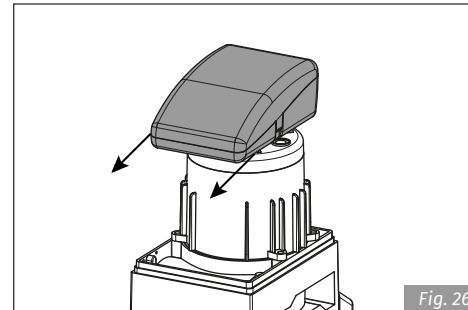

Fig. 26

- 2 • Access the adjusting screw. Slide the central box forward.

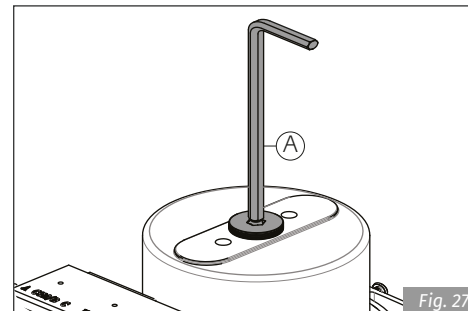

Fig. 27

- 3 • Adjust the screw in the upper part of the engine. To do this, it will require a 6mm umbrako key as shown in the image (A).

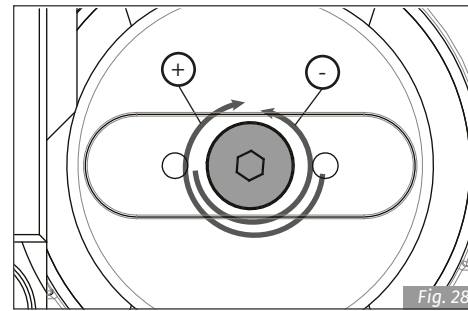

Fig. 28

- 4 • Do a test to the motor's irreversibility. To do that, just move the gate manually. If the gate is moving, it is necessary to refine the screw by turning clockwise (+).

If the gate does not move at idle, it means that the screw is tightened too much. Turn it counterclockwise (-) until the engine moves the gate at idle.

The tuning must achieve a balance between the gate's irreversibility and the engine's power.

04. CONNECTIONS OF THE MOTOR

FOR 800A/OL1500

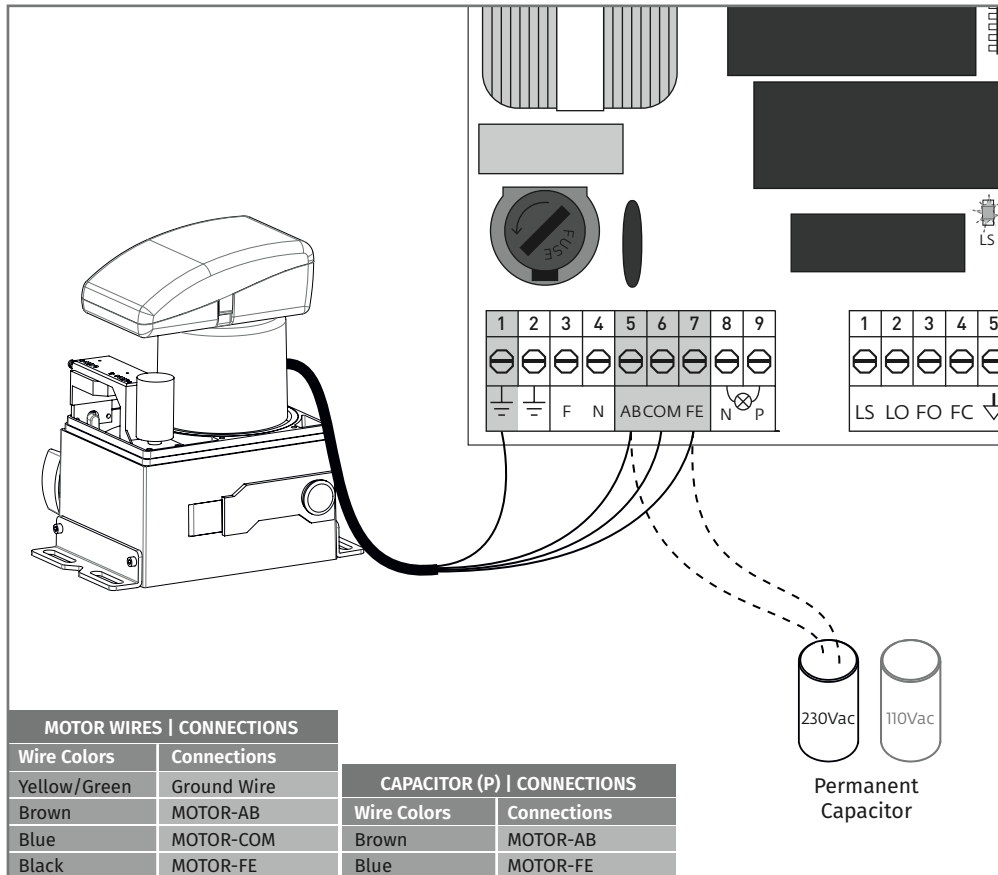

The motor connections must be made as shown above, by connecting the 4 motor wires to the appropriate inputs of the control board.

NOTE: The wires of the permanent capacitor (110Vac or 230Vac) must be connected directly to the control board as shown above.

04. CONNECTIONS OF THE MOTOR

FOR OL2000

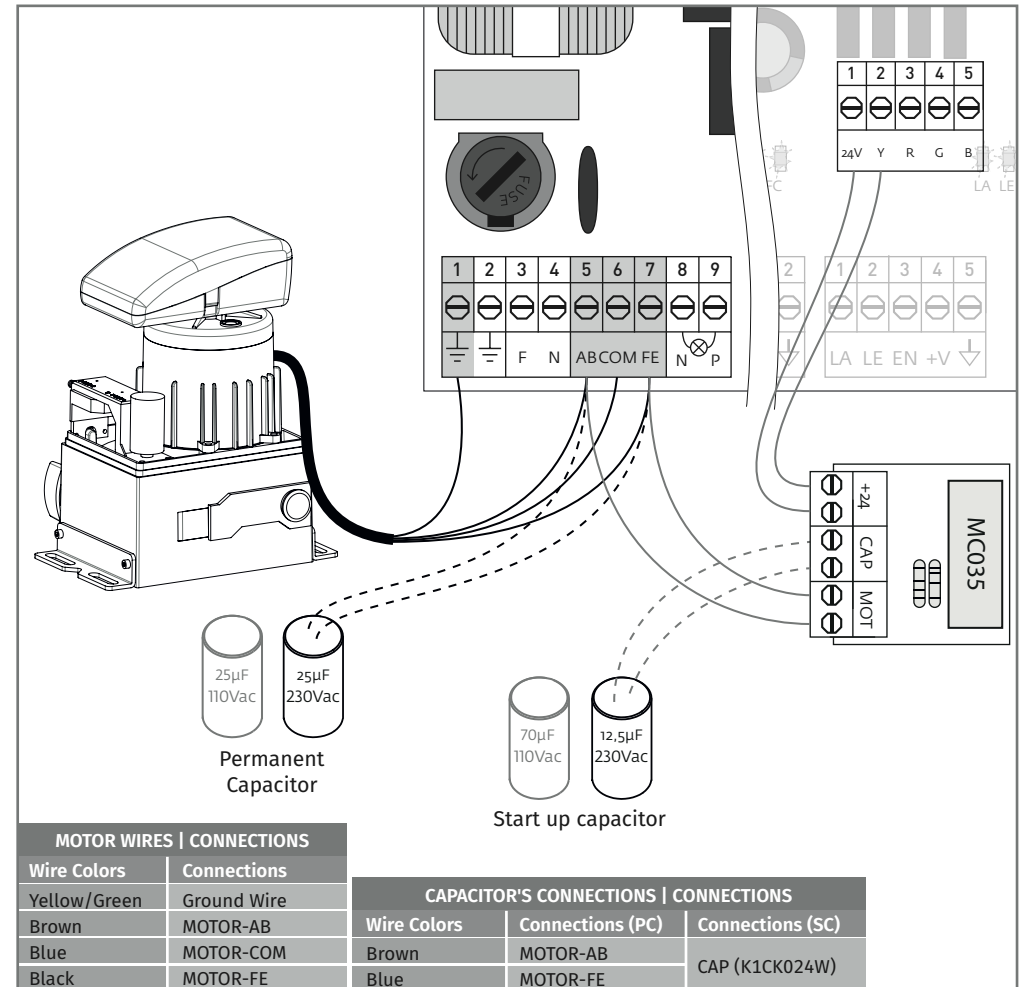

The motor connections must be made as shown above, by connecting the 4 motor wires to the appropriate inputs of the control board.

NOTE: In this motor you must use two capacitors, one of which works permanently and the other only works during the start up.

With 230Vac use 12.5uF + 25uF, and with 110Vac use 25uF + 70uF, connected as in the scheme above.